

# CONVERSIONS



Emma O'Kelly & Corinna Dean



LONDON'S SHOREDITCH AREA was originally known for its concentration of furniture makers, who produced intricate veneered cabinetwork and marquetry. Then it became run-down and depopulated, except for a few workers' cafés and a smattering of underground clubs and late-night bars. However, Shoreditch has fast gathered pace as one of the most fashionable creative neighbourhoods in London. A rash of interior-designed bars and the arrival of the White Cube gallery in Hoxton Square - promoting young British artists - confirmed the area's achingly cool status. Many of the light industrial warehouses have been converted into loft spaces, frequently with no trace of the building's original character. Instead cash greedy developers have carved up the buildings to produce cavernous 'loft-style' apartments. Arguably, the area is a victim of its own success.

A Berlin-based practice set up in 2003, magma architecture has an expertise in developing strong concepts for urban sites and designing temporary structures such as the pPod, an aluminium framed tent for the Horse and Bamboo Theatre, Manchester's travelling theatre company. For the loft in Shoreditch, magma were asked by the clients, a young couple from France and Italy, to maximize the living space within the existing shell of a 175 square metre (1,884 square foot) rooftop apartment located on Great Eastern Street, in the centre of Shoreditch.

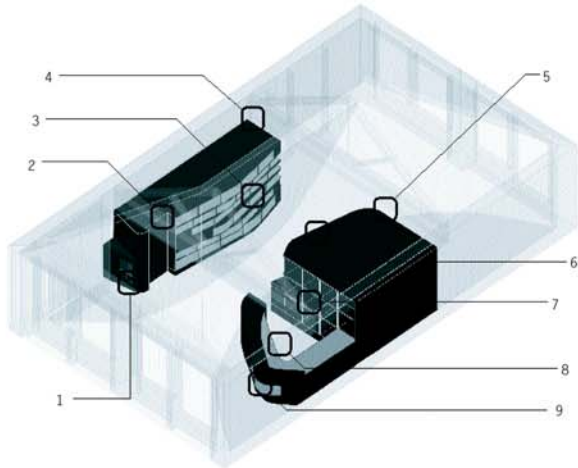

▲ DIAGRAM OF THE SOFTWALL UNITS:  
 1. CRYSTAL DISPLAY, 2. DOOR TO STAIRS DOWN, 3. BOOK LIGHT,  
 4. COAT CLOSET, 5. AMBIENT LIGHT,  
 6. BATHROOM DOOR, 7. COOKING COUNTER, 8. BAR COUNTER,  
 9. BOTTLE DISPLAY

▲ THE DOUBLE-HEIGHT SPACE FEATURES A MEZZANINE LEVEL, WHICH IS SUSPENDED FROM THE BUILDING'S EXISTING TIMBER TRUSS.

# EAST LONDON LOFT

magma architecture

London

UK